



# 1A 16-Port Power Supply Passive Receiver Hub

PN: H16P-RJ45BNCPS

## Description:

The 16 port power supply passive receiver hub allows transmission of video, power and PTZ control over CAT.5 or better UTP cable. The receiver hub supplies AC power to cameras via UTP cable over long distance. It has selectable 24VAC-OFF-28VAC switch allowing current supply up to 1 Amp per port, for 10 Amps aggregate.

It has a selectable 110/220VAC input with automatic reset fault protection and transient protection. The receiver hub can be used in association with a CCTV Power Thru balun.

## Features:

- 1) Selectable 110/220VAC input with automatic-reset fault protection and transient protection.
- 2) One data port provides PTZ telemetry / data signals which are paralleled together in groups of four, and passed through to RJ45 connectors in rear panel.
- 3) Switch is provided to select **24VAC-OFF-28VAC** individually for each port.
- 4) Each port supplies the current up to 1A max. Aggregate 10A max. for 16 ports.
- 5) LEDs built-in per channel which show load/no load, full load, and overload condition.
- 6) Electrical cut-off circuits **separately** for each port are provided while overload, short circuit to prevent damages.
- 7) Use with Power-Thru CCTV balun at the camera side.
- 8) Provide AC power to cameras via UTP over significant distances (See power distance chart).

## Rear & Front panel:

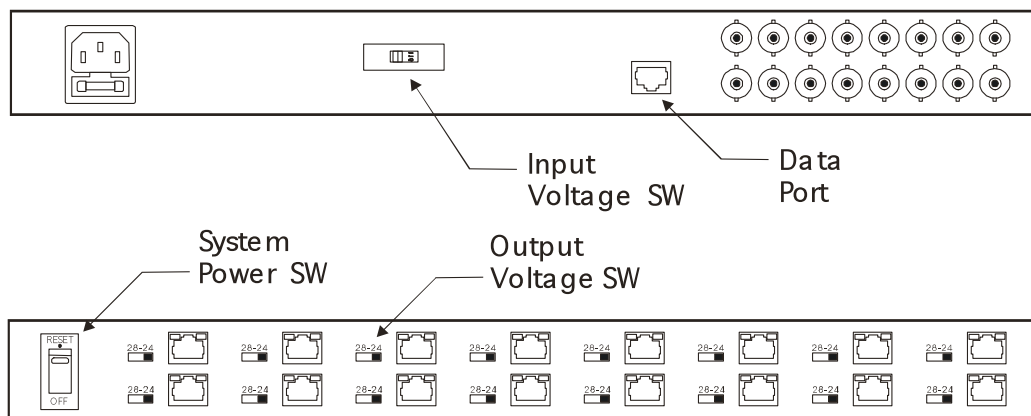

## Specification:

<b>Environment:</b>	Close-Circuit TV (CCTV) equipment for security and surveillance.		
<b>Devices:</b>	CCTV cameras, monitors, sequencers, multiplexers, digital video recorders (DVR) and other CCTV equipment.		
<b>Bandwidth:</b>	DC to 8MHz		
<b>Common Mode Rejection:</b>	60 dB typical over the frequency range		
<b>Power:</b>	<b>Power Input</b>	<b>Power Output</b>	
	Voltage: 110/220 Vac Watt: 325W Current: 2.5 / 1.25 Amps Heat: 250 BTU/hour	Each output are fully isolated 24Vac-Off-28Vac voltage switch Up to 1 Amp per camera (Aggregate up to 10Amps, No recommended to use neighbor ports for full load simultaneously to avoid transformer overheat.)	
<b>LED:</b>	LED Red: System Power	LED per channel:	<ul style="list-style-type: none"> <li>- OFF = no load connected</li> <li>- GREEN = load connected and working</li> <li>- GREEN+AMBER: Full load</li> <li>- Amber: Overload fault condition</li> </ul>
<b>Cable-UTP:</b>	UTP Cat. 5 or better, AWG #24 typically Impedance: 100 ohms Max. Cap.:20pf/ft Attenuation: 6.6dB/1000 ft. at 1MHz		
<b>DC Loop Resistance:</b>	CAT.5		Loop Resistances/100 M
	20 AWG (0.7mm)		7 ohms
	22 AWG (0.6mm)		11 ohms
	24 AWG (0.5mm)		18 ohms
<b>Cable-Coax:</b>	Impedance: 75 ohms at 1MHz (RG59/U) Max. 25ft. of coax allowed per end to end link		
<b>Connectors:</b>	BNC female: 75 ohms    RJ45 jack:100 ohms		
<b>Maximum distance for power:</b>	(@ 24Vac power output over AWG#24 UTP cable) 100mA: 240m 300mA: 80m 1000mA: 24m <i>(longer distance can be reached when power output @28Vac)</i>		
<b>Temperature:</b>	Operating temp. 0 to 55° C Storage temp. -22 to 85° C Humidity up to 95%		
<b>Minimum airflow:</b>	20ft <sup>3</sup> /min (0.5m <sup>3</sup> /min)		
<b>RJ45 wiring output to camera:</b>	Camera 1 to camera 16: Video: 7+/8-    Power: 1,3+/2,6-    PTZ: 4+/5-		
<b>RJ45 wiring PTZ Input:</b>	Camera 1 to camera 4: PTZ A: 1+/2-,	Camera 5 to camera 8: PTZ B: 5+/4-,	Camera 9 to camera 12: PTZ C: 3+/6-, Camera 13 to camera 16: PTZ D: 7+/8-,
<b>Power reset Function</b>	The electrical cut-off circuits will be activated and locked to prevent damage, slide the power output switch to "OFF" and return back after solving out the problem of over load and/or short circuit.		
<b>Dimension</b>	435*320*45 in mm Metal case only, connectors not included.		
<b>Weight</b>	10Kg		

## Installation

1. **Do not plug in the power cord and keep system power switch to “OFF” prior to completing all installations.**
2. Set input voltage switch (in red color located by BNCs) to 115Vac or 230Vac to meet the local power source.
3. Set output voltage switch among 24Vac, OFF and 28Vac, refer to Maximum distance for power and Power reset function in specification.
4. Connect BNC connectors to DVR individually.
5. Connect UTP cables between 16 ports power supply passive panel and power thru Baluns at cameras' side.
6. Connect PTZ control signals into RJ45 data port on 16 ports power supply passive panel.
7. Connect power thru Baluns to cameras individually.
8. Plug the power cord IN.
9. Turn ON system power switch.

## Trouble Shooting

1. No function and/or poor image:
  - Check if the power input slide switch is on right position.
  - Check if the transmitted distance is over specification.
  - Check if wirings are correct.
  - Check LED indicators to see if overload and/or short circuits exist.
2. Poor quality of UTP cable might affect the function, replace with qualified Cat.5e cable or better.

## Application

